

I. Warning

To avoid fire or electrical shock, do not expose this product to rain or moisture.

To avoid short circuit, be sure the batteries contacts are securely packed and in accordance with local provision when handling the batteries.

Please place the batteries and the parts which can be swallowed mistakenly away from children. Contact a doctor immediately when it occurs.

To avoid possible injury to eyes, do not use the flash light in a short distance from the eyes.

To avoid possible safety accident, do not use the flash light on the people who need a high degree of attention.

Please take out the batteries and stop using immediately in case of below.

- This product is dropped or shocked seriously and the inner part of the product is bared.
- If the battery leaks corrosive liquids, please take out the battery with gloves.
- The product gives off strange smell, smokes or heats.

Do not disassemble or maintain this product. Touching the internal high voltage circuit will cause electric shock.

Remove batteries during long periods of non-use.

II. Features

- **AWL SUPPORTED FOR N's & C's SYSTEM**

The YN560EX can be triggered by 580EX II, SB-900/800/700, 7D/60D/600D, Nikon C-command, SU-800 and ST-E2, support 4 channels, and flashes as TTL mode as well as M mode.

- **ULTRA LARGE LCD PANEL**

Large LCD panel, you can set and look into the functions on the LCD panel clearly and directly.

- **GN58 @ ISO100, 105 mm**

A new speedlite with high guide number which supports TTL, M, Multi mode.

- **MULTIPLE TRIGGER MODE SUPPORTED**

YN560EX can be triggered by hot-shoe, flash command slave mode, optical S1, S2 (pre-flash-canceled mode).

- **PROVIDES POWER ZOOM FUNCTION**

The YN560EX covers a focal length of 24 to 105mm by operating zooming button.

- **SUPPORTS REMOTE TTL FUNCTIONS**

In the case of remote mode, FEC, FEB, Rear-curtain sync, FE lock is supported.

- **REMOTE WIRELESS TRIGGER SUPPORTED**

The YN560EX supports remote wireless trigger function, which makes the Sc/Sn/S1/S2 mode can be used in outdoor environment and the wireless trigger distance is as long as 15 meters.

- **SOUND PROMPT SYSTEM**

Turn on the sound prompt function, different sounds indicate working situations help you focus on shooting (please not that the sound can be shut down).

- **2.5mm TYPE PC PORT PROVIDED**

YN560EX provides the standard 2.5mm type PC port, you can make the flash synchronously by connecting to the PC port.

- **SUPER SPEED OF CHARGING RECYCLE**

It only takes 3 seconds to finish a charging cycle after a full level output. Even without new batteries, you can get super charging speed that it only needs 4 to 5 seconds.

- **ADVANCED SETTING ON FLASH**

YN560EX supports advanced settings, you can customize the unit according to your shooting preferences.

- **THE AUTOMATIC SAVING SETTING**

The YN560EX can automatically save the current setting in order to let you have a simpler use next time after boot.

III. Quick Start

If you don't have much time to read the whole user manual, we advise you to read this section.

1. Please avoid the excessive use of the output with maximum power. It can effectively extend the service life of this product.
2. You can understand the function of each button by pressing them and observing the displayed content.
3. Press the [MODE] button to select Sc/Sn/S1/S2 mode.
4. Press the [UP], [DOWN], [LEFT], and [RIGHT] buttons to adjust the parameters of speedlite quickly at the current mode. For some parameters, the [OK] button in the center is needed to be pressed for setting.
5. Keeping [ZOOM] button to set the function of advanced option of speedlite. See the section of “Advanced Setting” for the content.
6. This product provides M, Multi, and remote TTL mode.

IV. Nomenclature (Please read this part carefully, so you can soon be familiar with the product)

1. Reflection board
2. Wide-angle diffuser
3. Flash head
4. PC port (for input)
5. Contact cover
6. Battery chamber's cover
7. Wireless trigger sensor
8. Remote indicator
9. Locking ring
10. Hot shoe stand
11. Sound port
12. Hot shoe contact

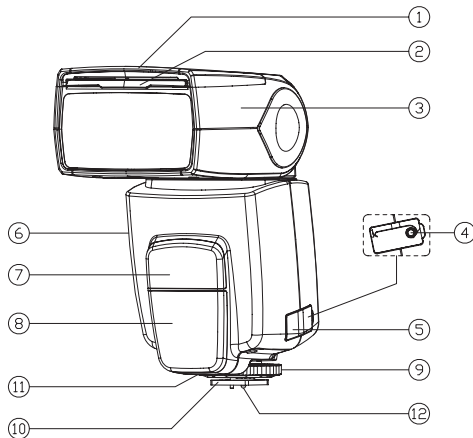

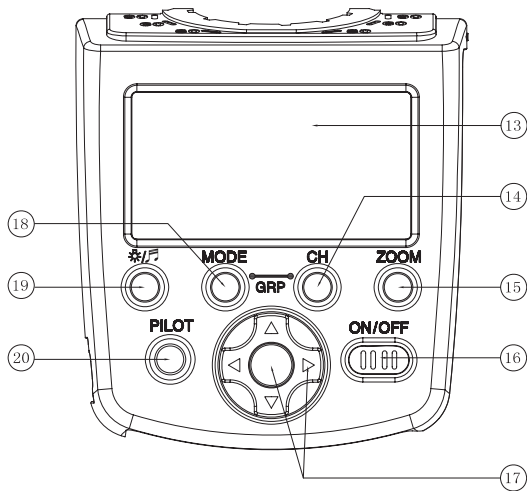

13. LCD panel: It will display the status of function settings.

14. Channels setting button (CH): In the case of Sc/Sn mode, you can adjust the channels (1, 2, 3, 4) through [CH] button. In the case of M/Multi/S1/S2 modes, press [CH] button to adjust the zooming range.

15. ZOOM button: You can adjust the zooming range (24, 28, 35, 50, 70, 80, 105mm) by operating the [ZOOM] button directly. Keeping [ZOOM] button to set the function of advanced option of speedlite.

16. Power switch: Turn on or turn off the power of speedlite by putting [ON/OFF] button.

17. Selecting/setting button group: Buttons of multi functions include LEFT, RIGHT, UP, DOWN and OK buttons; it is applied to adjust output, Stroboscopic flash count, Stroboscopic flash frequency, the fine tuning of output power, and advanced settings.

18. MODE switch button: The mode of the speedlite will be switched among the M/Multi/Sc/Sn/S1/S2/ in circle for each press.

19. Illumination/Sound switch: A short press will turn on or turn off the LCD panel illumination light, a long press will turn on or turn off the sound prompt function.

20. Charging indicator/ Test button (PILOT): The lighting of red light shows that the charging process is finished and speedlite can be used, the lighting of green shows that it is in charging or a shortage of power; If you press this test button (PILOT), the speedlite will give a test flash.

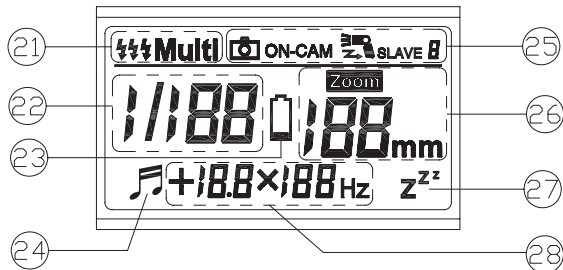

21. Mode indicator

22. Output levels indicator

23. Power low indicator

24. Sound prompt

25. Flash trigger model

26. Zooming indicator

27. Sleeping indicator

28. Frequency, flash times and the tuning of output level indicator

V. Installation Instruction

1. Install Batteries

Slide the batteries chamber's cover in the direction of the arrow.

Insert the batteries according to the label inside battery chamber.

Make sure the direction of the batteries' polarity is correct.

Close the battery chamber cover in the direction of the arrow.

2. Attaching to the Camera

Loosen the locking ring by turning it in the direction of the arrow.

Slip the speedlite hot shoe stand into the camera hot shoe stand until it stops.

Turn the locking ring in the direction of the arrow tighten.

To detach the speedlite, loosen the locking ring by turning it in the opposite direction.

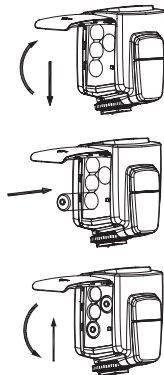

VI. Basic Functions

1. Basic Operations

Operation of the buttons:

Component	Operation
[Power Switch]	Power switch of the speedlite. The power of the speedlite can be turned on or turned off by pressing [Power Switch] button. It is suggested that the batteries should be taken out after the power of the speedlite is turned off through this button.
[Mode Switch Button]	The mode of the speedlite will be switched among the M/Multi/ Sc/Sn/S1/S2 in circle for each press.
Illumination/Sound Prompt Switch]	A short press will turn on or turn off the LCD panel illumination light, a long press will turn on or turn off the sound prompt function.
[CH] button	In the case of Sc/Sn mode, you can adjust the channels (1, 2, 3, 4) through [CH] button. In the case of M/Multi/S1/S2 mode, you can adjust the zooming range by this button.
[ZOOM] button	You can adjust the zooming range (24, 28, 35, 50, 70, 80, 105mm) by operating the [ZOOM] button directly.
[Selecting/Setting button group]	Buttons of multi functions include LEFT, RIGHT, UP, DOWN and OK buttons; it is applied to adjust output, Stroboscopic flash count, Stroboscopic flash frequency, the fine tuning of output power and advanced settings.
[PILOT] button	If you press this test button (PILOT), the speedlite will give a test flash.

Meaning of [Charging indicator]

Status of [Charging Indicator]	Meaning	Operation
The red light is lit	The speedlite is fully charged, and can be used.	Normal
The green light is lit	The speedlite has not been fully charged.	Waiting for the completion of charging.
The green light blink	The power is not enough, and the speedlite is about to shut down.	Please replace the batteries.

The meaning of [Sound indicator]

The sound form	Meaning	Operation
Tick twice	a. The sound indicator is enabled; b. The speedlite is started or flash is ok.	Normal
Three tick, two times	The exposure may be over	Adjusting exposure compensation or charging shooting condition
Tick tick tick	The exposure may be excessive	Adjusting exposure compensation or charging shooting condition
Tick—tick twice—tick twice	The speedlite is in the charging or overheating protection state.	Waiting for the completion of charging; waiting for about 3 minutes to cancel the protection.
Tick—a long sound	The speedlite is fully charged, and can be used.	Normal
Tick—tick —tick	The power is not enough and the speedlite is going to be shut down.	Replace the batteries.

2. Power-on and Power-off

The power of the speedlite can be turned on or turned off by pressing [Power Switch] button 2 seconds. It is suggested that the batteries should be taken out after power of speedlite is turned off though this button.

After turned on the power of the speedlite, the charging indicator is red, which indicates the speedlite is available.

If the charging is not completed within 20 seconds, the low power indicator will be displayed on LCD panel, and speedlite will automatically shutdown, you need to replace with new batteries.

You may press the [PILOT] button to test whether the speedlite works normally.

After use, turned off the speedlite by pressing the [Power Switch] button.

3. M Mode

In M mode, you can set the speedlite output levels as you like. By [LEFT] [RIGHT] [UP] [DOWN] buttons, you can adjust output levels from 1/128 to 1/1 full power in 1/3-stop, 1/2-stop or mix increment, there are 8 levels of output and each level has 3 fine tuning stalls, up to a total of 29 fine turning. Press [LEFT] and [RIGHT] button to adjust output level, you can fine tune the power output of the flash by [UP] and [DOWN] buttons, and the states of setting will be displayed on LCD panel.

Adjust the camera and press the shutter, the speedlite will flash with the synchronic signal of the camera..

4. Multi Mode

With Multi mode, a rapid series of flashes is fired. The speedlite will flash according to the output levels, flash times and frequency you set. Use [LEFT], [RIGHT] buttons to adjust output power, flash times and frequency. The adjustment scope of output level is 1/128-1/64-1/32-1/16-1/8-1/4, the scope of flash times is from 1 to 100, and the scope of flash frequency is from 1

to 100. Adjustment method: Please press [OK] button to select setting items (flash) and use the [LEFT] and [RIGHT] buttons to adjust the parameters. After the setting is completed, press [OK] button to confirm the setting.

NOTE: The charging speed of speedlite is slow under the situation that the electricity quantity of the battery is insufficient, which may cause the occurrence of the high-frequency flash. Please reduce the flash frequency or change new battery under this situation.

5. Sc/Sn and S1/S2 Mode

To select SLAVE c/SLAVE n/SLAVE1/SLAVE2/ (Sc/Sn/S1/S2) mode by pressing [MODE] button. These four modes are use as slave units, you can create various lighting effects with the wireless slave units. When using Sc/Sn/S1/S2 mode, you can rotate the flash head to make the wireless triggering sensor face with the master flash.

Sc/Sn mode: YN560EX can be triggered by 580EX II, SB-700/800/900, 7D/60D/600D, Nikon C-command, SU-800 and ST-E2 respectively, and flashes as TTL mode as well as M/Multi mode. Both the master and slave units must be set to the same channel .On the YN560EX, you can adjust the channels (1, 2, 3, 4) by pressing [CH] button, and the output level of speedlite is completely controlled by master unit.

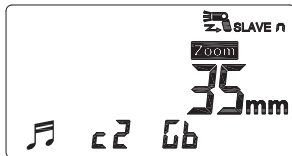
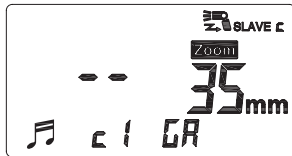

S1 and S2 modes are suitable for MANUAL flash environment and TTL flash environment respectively. Under these two modes, the way to adjust the output level is like that in M mode.

S1 mode: It will work with the first work of the master flash synchronously, with the result consistent with the use of radio slave. To use this mode correctly, the master flash should be set at manual flash and the TTL flash system with preflight function and the red-reduction function with multiple flashes should not be used.

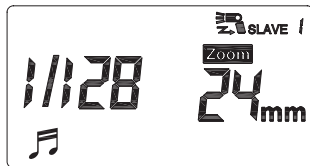

S2 mode: It is also called “pre-flash cancel mode”. This mode is similar with S1 mode, but it can neglect the pre-flash given by TTL flash. Therefore, it can support the main flash working in TTL mode. In particular, if S1 mode cannot flash correctly and synchronically with your internal flash, you can try to use S2 mode.

The following situation shall be avoided when the S1 and S2 modes are used: the red eye reduction function of the main light is used; the order mode (nikon) or wireless mode (canon) of the main light is used; the ST-E2 is used as the flash controller.

Otherwise, please set the speedlite as Sc/Sn.



6. Test Flash

Whether in any mode, you can press PILOT button to test if the speedlite flash normally. When testing the flash, the speedlite will give flash at relevant output level in accordance with the chosen output power setting.

7. Power Saving Mode

YN560EX provides shrinkable power-saving mode; this power-saving mode can be set through pressing [Advanced option] button, the default setting <SE Sd 3 30> for example. You can customize different power-saving timing to suit your preferences. In M/Multi mode, the speedlite keeps idle for 3/15/30/-- minutes and then it will step into the dormancy state in order to save power, and powers off automatically after keeping idle for 30/60/120 minutes. Under the dormancy situation, you can awake the speedlite by pressing any button.

In Sc/Sn/S1/S2 mode, no dormancy, and the speedlite will automatically shut down after keeping idle for 30/60 minutes.

NOTE: When it is set as <SE Sd - - 120>, this means NO DORMANCY.

Flash mode	Sleep timing	Automatic shutdown timing
M/Multi	Keeping idle for 3/15/30/-- minutes will enter the dormancy mode (-- means no dormancy)	The speedlite will be automatically shut down after keeping idle for 30/60/120 minutes.
Sc/Sn/S1/S2	No dormancy	The speedlite will be automatically shut down after keeping idle for 30/60 minutes.

8. Overheating Protection

If the speedlite is used too frequently, its overheating protection function will be triggered, at the moment, <O.H> is displayed on LCD panel, and the speedlite is locked. In such case, please wait for about 3 to 5 minutes to cancel the protection before continuing the use. Please try to use the 1/4 output or lower when rapid shooting is needed to prevent the effect on the shooting.

9. Manually set the zooming position

You can manually set the zooming position. The coverage focal length of the speedlite will be switched in circle of (24, 28, 35, 50, 70, 80, 105mm) by pressing [ZOOM] button. What's more, the coverage focal length will be displayed on the LCD panel directly.

10. Sound Prompt

When the sound prompt function is activated, the speedlite will give out different sound to indicate the working state. See the following table for the meaning of sound.

The sound form	Meaning	Operation
Tick twice	a. The sound indicator is enabled; b. The speedlite is started or flash is ok.	Normal
Three tick, two times	The exposure may be over	Adjusting exposure compensation or charging shooting condition
Tick tick tick	The exposure may be excessive	Adjusting exposure compensation or charging shooting condition
Tick—tick twice—tick twice	The speedlite is in the charging or overheating protection state.	Waiting for the completion of charging; waiting for about 3 minutes to cancel the protection.
Tick—a long sound	The speedlite is fully charged, and can be used.	Normal
Tick—tick —tick	The power is not enough and the speedlite is going to be turned off	Replace the batteries.

11. 2.5mm type PC Sync port (for input)

By connecting to the PC sync port, you can make the flash synchronously.

12. Automatic setting saving

The speedlite will automatically save the current settings in order to let you have a simpler use next time after boot.

VII. Wireless Flash System

YN560EX has wireless remote flash systems as slave unit, the YN560EX can be triggered by 580EX II, SB-900/800/700, 7D/60D/600D, Nikon c-command, SU-800 and ST-E2, wireless TTL or manual lighting can be achieved.

c: Indicating that it can only receive wireless signal from Canon system, avoiding Nikon system.

n: Indicating that it can only receive wireless signal from Nikon system, avoiding Canon system.

Any flash exposure compensation, FEB, FE lock, manual flash, and stroboscopic flash settings set with the master unit will be automatically transmitted to the YN560EX.

Even with multiple YN560EXs, all of them will be controlled in the same way via wireless.

1. Master unit setting

To use 580EX II, SB-900/800/700, 7D/60D/600D with built-in commander mode, Nikon c-commander, SU-800 and ST-E2. For the setting method, please refer to your master instructions.

2. Slave unit setting

As the slave unit, when YN560EX is used, the wireless option of speedlite is set as SLAVE c or SLAVE n.

Setting method: Press [MODE] button to select SLAVE c or SLAVE n, please press [MODE] button first for a while and then press [CH] button to select slave group (A, B, C), and you can select channels(1,2,3,4) by pressing [CH].

3. Multi-Speedlite, Wireless lighting configurations

You can create two or three slave groups to make shooting effect better meet your requirements, and set flash ratio for TTL autoflash shooting of master, as well as manual flash output, frequency flash etc.

(1). Wireless flash of two slave units made up by YN560EX .

- Wireless option setting: SLAVE c/SLAVE n for operation
- Communication Channel setting: 1, 2, 3, 4
- Groups setting: Set one YN560EX as group A, and set the other one as group B.
- Master unit setting: Set the communication channel, Set the flash ration of master unit A: B or A: B C. You can conduct flash shooting.

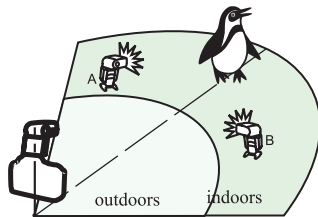

(2). Wireless flash with three YN560EX speedlites

- Wireless option setting: SLAVE c/SLAVE n
- Channel setting: 1, 2, 3, 4
- Groups setting: Set three YN560EX speedlites as group A, group B and group C respectively.
- Setting master and shooting: Please select the ratio <A: B C>.

Press the test button of master to test whether the flash works normally; if the flash does not fire, adjust the slave unit's angle toward the master unit and distance from the master unit.

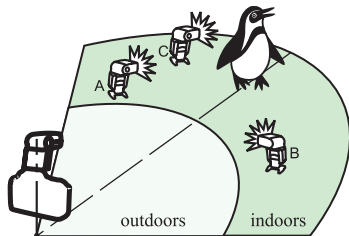

NOTE: If ratio <A: B> is set, the slave unit in group C will not fire.
If you have the slave group set to <A> for three slave units, all three slave units will be controlled as if they were one speedlite in slave group A.

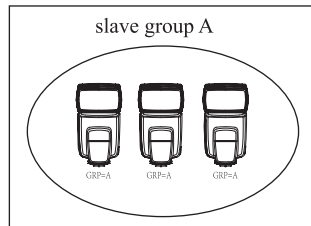

4. Manual Flash and Stroboscopic Flash with Wireless

As the slave unit, YN560EX supports manual flash and stroboscopic flash.

Manual flash: Set the master unit's flash mode to <M>, and set the flash output on master unit.

Stroboscopic: Set the master unit's flash mode to < Multi>, and set the flash output, stroboscopic flash count, stroboscopic flash frequency on master unit.

5. Shooting Examples with Wireless Flash System

- Master unit: 580EX II, SB-900/800/700, 7D/60D/600D with built-in commander mode, Nikon c-commander, SU-800 and ST-E2.
- Slave unit: YONGNUO EX series flash, you can create three slave groups at all.
- Use the mini flash stand (tripod socket provided) to prop up the YN560EX speedlite.
- Swing the YN560EX so that its wireless sensor faces the master unit.
- Indoors, the wireless signal can also bounce off the wall so there is more leeway in positioning the YN560EX(s).
- After positioning the YN560EX(s), be sure to test the wireless flash operation before shooting.
- Don't place any obstacles between the master unit and slave unit(s). Obstacles can block the transmission of wireless signals.

VIII. The Advanced Application

1. Ultra-long-range Wireless Flash

YN560EX can receive remote wireless signal. The longest distance used indoors is 25 meters and the longest distance used outdoors is 15 meters.

Please note that the YN560EX's wireless sensor should be faced to master unit, and make sure it is within the effective range of transmission.

NOTE: As the slave unit, when YN560EX is used as Sc/Sn, the output level of speedlite is completely controlled by master unit.

2. Flash Exposure Compensation

You can use the exposure compensation function of the camera to compensate flash output so as to make shooting effect better meet your requirements. Please set the exposure compensation on your master unit, refer to your master user manual for setting.

3. Rear- curtain Sync

You can use slow-speed shutter to produce trailing smear for the object and the flash light will flash at the moment when the shutter is going to be shut, which means the rear-curtain sync function .(For the rear-curtain sync setting, refer to your camera manual for setting).

NOTE: For canon wireless flash system, when YN560EX is used as slave unit, the rear-curtain sync function cannot be set.

4. Exposure Bracketing (FEB)

The FEB function is set on the camera or master unit. For the specific setting method, refer to your camera or master unit's instructions. After the FEB is set, after 3 photos are taken, exposure compensation will be made automatically in the sequence of, for example, "normal → under → over". This function helps you improve the success rate of photo taking.

NOTE: For FEB, set the camera's drive mode to single shooting. Be sure the flash is ready before shooting.

5. FE Lock (Canon)

To use this function, cover the subject for which flash exposure will be locked at the center of the viewfinder of camera, press the button <*> of the flash exposure lock, and the flash light will pre-flash and the camera will calculate the appropriate flash output data. Now you have some time for decomposition, after which, you can take photo. (The function can be used only when it is supported by your camera. For the setting method, refer to your Camera Instructions.)

6. FV Lock (Nikon)

Set the AE-L/AF-L function as FV Lock on the camera before using this function. At this time, you can aim at your desired object in the viewfinder and then press the AE-L key or AF-L key, in such case, the flash light will pre-flash to get the reading of flash exposure for the object; after you have confirmed the scene frame, press the shutter. (This function can only be available when your camera supports it; for the setting of AE-L and AF-L, refer to your camera manual).

7. Advanced Setting

The YN560EX provides advanced settings, you can customize speedlite feature to suit your shooting preferences. Set the advanced settings through [ZOOM] button. Setting methods: Press the [ZOOM] button until it enters the advanced option setting state. Select setting item through [UP] and [DOWN] button; for example, <SE Sd 3 30> means keeping idle for 3 minutes will enter the dormancy mode and 30 minutes will automatically shut down the speedlite.

The meanings of the items can be found in the table below:

SE Sd 3/15/30, 30/60/120: Keeping idle for 3/15/30 minutes will enter dormancy mode and keeping idle for 30/60/120 minutes will automatically shut down the speedlite.

SE Sd -- 120: No dormancy, the speedlite will be automatically shut down after keeping idle for 120 minutes.

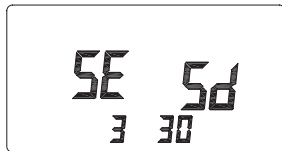

SLAVE Sd 30: Power automatic off of the slave unit is 30 minutes.

SLAVE sd 60: Power automatic off of the slave unit is 60 minutes.



Inc 0.3: 0.3ev for fine-tuning step

Inc 0.5: 0.5ev for fine-tuning step

Inc 0.3&0.5: Mix 0.3ev and 0.5ev for fine-tuning step

lcd 7/15/30: The display time of LCD backlight is 7/15/30 seconds

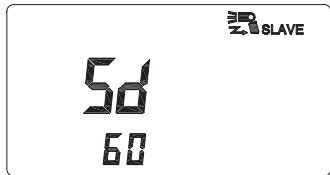

qu - -: Quick turn on / shut down function is disabled

qu on: Quick turn on / shut down function is enabled

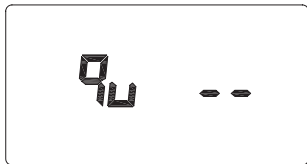

8. High-speed continuous shooting

The flash can realize the high-speed continuous shooting function. Please set the camera in the continuous shooting form and then shoot.

Please note: The number of photos that can be continuous shot is related with the output level. Please use the fully charged battery.

9. Reflection Flash

Bounce flash means to take photos by making flash light head aimed at wall or ceiling and using the light reflected back from the ceiling or wall to light the desired object, so that the shade behind the object can be decreased to get more natural shooting effect.

If the wall or ceiling is too far, the bounce flash may be too weak to get enough exposure. The wall or ceiling should be even and white in order to get efficient reflection; if the reflection surface is not white, color cast may appear in photo.

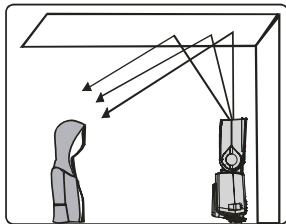

10. Use Reflection Board to Take Photos

With the reflection board flash, draw the reflection board and the wide-angle diffusion board out from the light head at the same time and then push the wide-angle diffusion board back. In such case, if this product is being used to take photos, it will produce a highlighted point on the eyes of the subject and thus make the eyes charming (catch light). This function can reach optimal effect when the flasher head is up 90°.

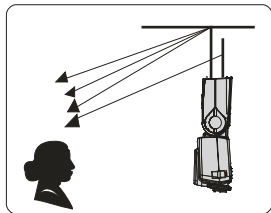

11. Use Wide-angle Diffuser

Pull out the wide-angle diffusion board, push back the reflection board and arrange them as per the figure; in such case, the flash scopes will extent to 18 mm and the flash effect will be softer and more natural.

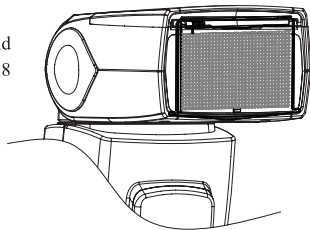

IX. Specifications

Circuit design	Insulated Gate Bipolar Transistor (IGBT)
Guide No.	58 (ISO 100, 105mm)
Flash mode	M, Multi, Sc, Sn S1, S2
Zoom range	24, 28, 35, 50, 70, 80, 105mm
Vertical rotation angle	-7~90 degrees
Horizontal rotation angle	0~270 degrees
Power supply	4×AAsize batteries (Alkaline or Ni-MH are usable)
Lighting times	100~1500 times (AA alkaline cell used)
Recycle time	Approx 3s (AA alkaline cell used)
Color temperature	5600k
Flash time	1/200s~1/20000s
Flash control	8 levels of output control (1/128~1/1), 29levels of fine tuning
External interface	hot shoe, PC port
Wireless triggering distance	20~25m indoor, 10~15m outdoor
Additional features	Rear-curtain sync, FEC, FEB, FEV, the electronic flash head zooming, sound prompt, automatically saving setting, PC port, power saving mode, over heat protection, advanced setting.
Dimensions	60×73×190mm (Extended state)
Net weight	350g
Accessories	Flash light (1), protecting bag (1), mini stand (1) and manual (1)

Guide Number of different focal length range (at ISO 100, in meters / feet)

Flash Output	Flash Coverage (mm)							
	14	24	28	35	50	70	80	105
1/1	15/49.2	28/91.9	30/98.4	39/127.9	42/137.8	50/164	53/173.9	58/190.3
1/2	10.6/34.8	19.8/65	21.2/69.6	27.6/90.7	29.7/97.4	35.4/116.1	37.5/123	41/134.5
1/4	7.5/24.6	14/45.9	15/49.2	19.5/64	21/68.9	25/82	26.5/86.9	29/95.1
1/8	5.3/17.4	9.9/32.5	10.6/34.8	13.7/45.2	14.8/48.6	17.7/58.1	18.7/61.4	20.5/67.3
1/16	3.8/12.5	7/23	7.5/24.6	9.7/32	10.5/34.4	12.5/41	13.3/43.6	14.5/47.6
1/32	2.7/8.9	4.9/16.1	5.3/17.4	6.9/22.7	7.4/24.3	8.8/28.9	9.4/30.8	10.3/33.8
1/64	1.9/6.2	3.5/11.5	3.8/12.5	4.9/16	5.3/17.4	6.3/20.7	6.6/21.7	7.3/24
1/128	1.3/4.3	2.5/8.2	2.7/8.9	3.5/11.4	3.7/12.1	4.4/14.4	4.7/15.4	5.1/16.7

X. Possible problems during use and solutions

- 1. Please note when use the flash outdoors:** For outdoor application, please avoid direct sunlight to the wireless triggering sensor and ensure normal use of the flash.
- 2. Precaution for outdoor use of lambency umbrella:** The lambency umbrella mounted on the flash light outdoors may be blown down easily, and the hot shoe of the flash light may be broken. Please fix the mounting rack or avoid outdoor use.

3. Photos are under exposure or over exposure? Check if the set shutter, aperture and ISO are too near the flash limit or if some settings including exposure compensation in relation to flash are proper.

4. Vignetting appears in photos or only part of the subject is illuminated? Please check the current coverage of focal length and make sure if the lens focal length exceeds the coverage range of the flash. The product's zooming range is 24~105mm of the medium format system. You can try to pull out the wide-angle diffuser to expand the flash range.

5. You may feel the flash control panel is dim, because there is one protective film on the panel; you can tear it away to enjoy a clear visual effect.

6. The flash light is abnormal? Switch off the power of flash light and camera, mount the flash light on the hot shoe of camera, and switch on the power of flash light and camera again. If the abnormality continues, replace the batteries.

Update version of this manual can be got form http://www.yongnuo.com.cn/usermanual/downloadIndex_en.htm

The functions of this manual are based on test conditions of our company. Further notice will not be given if the design and specifications change.

The YONGNUO logo in this manual includes the registered trademark or trademark of **SHENZHEN YONGNUO PHOTOGRAPHY EQUIPMENT Co., Ltd** in China or/and other countries (regions). All other trademarks are the property of their respective owners.